



UNIVERSITY OF CAMBRIDGE INTERNATIONAL EXAMINATIONS  
General Certificate of Education Ordinary Level

CANDIDATE  
NAME

CENTRE  
NUMBER

--	--	--	--	--	--

CANDIDATE  
NUMBER

--	--	--	--	--



**COMBINED SCIENCE**

**5129/02**

Paper 2

**October/November 2008**

**2 hours 15 minutes**

Candidates answer on the Question Paper.

No Additional Materials are required.

**READ THESE INSTRUCTIONS FIRST**

Write your Centre number, candidate number and name on all the work you hand in.

Write in dark blue or black pen.

You may use a soft pencil for any diagrams, graphs or rough working.

Do not use staples, paper clips, highlighters, glue or correction fluid.

**DO NOT WRITE IN ANY BARCODES.**

Answer **all** questions.

A copy of the Periodic Table is printed on page 20.

At the end of the examination, fasten all your work securely together.

The number of marks is given in brackets [ ] at the end of each question or part question.

**For Examiner's Use**

This document consists of **17** printed pages and **3** blank pages.



1 The following is a list of gases.

ammonia      argon      chlorine      hydrogen  
nitrogen      sulphur dioxide

Complete the following sentences using the gases from the list.

Each gas may be used once, more than once, or not at all.

(a) A gas that causes erosion of buildings is ..... [1]

(b) A gas that displaces bromine from potassium bromide is ..... [1]

(c) A gas used in the manufacture of margarine is ..... [1]

(d) A gas used in the purification of water supplies is ..... [1]

(e) A gas that dissolves in water to give an alkaline solution is ..... [1]

2 A student connects a cell, a lamp, a variable resistor and an ammeter in series.

(a) In the space below, draw the circuit diagram.

[3]

(b) For one setting of the variable resistor, the lamp has normal brightness. The student increases the resistance of the variable resistor.

State what, if anything, happens to

(i) the potential difference across the lamp, .....

(ii) the brightness of the lamp. .... [2]

3 Fig. 3.1 represents the human alimentary canal.

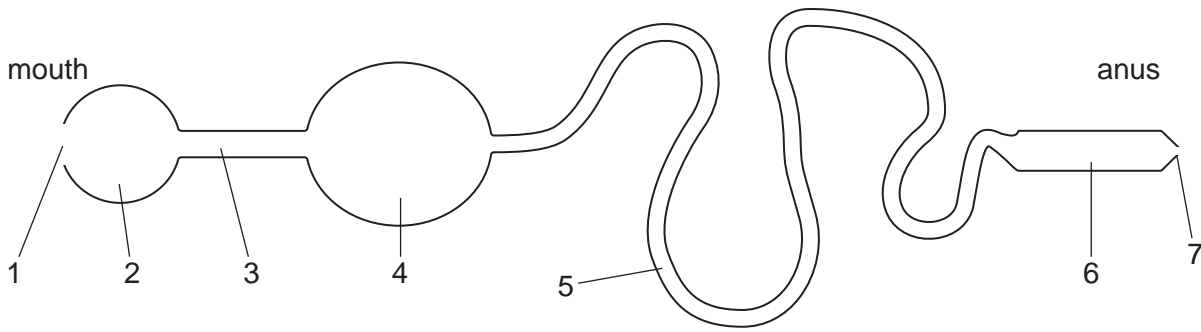

**Fig. 3.1**

(a) State the number of the region where each of the following processes occurs.

(i) absorption .....

(ii) digestion .....

(iii) egestion .....

(iv) ingestion .....

[4]

(b) State

(i) the process that moves food through region 5,

..... [1]

(ii) the part of a balanced diet that helps this process.

..... [1]

(c) Saliva is secreted into the mouth.  
State two functions of saliva.

1. ....

2. .... [2]

4 Air is a mixture of gases.

(a) Fig. 4.1 shows the percentages of different gases in air.

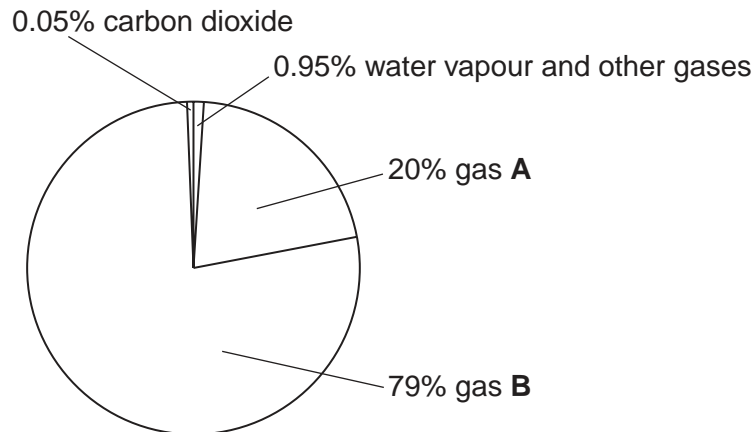

Fig. 4.1

State the name of

gas **A**, .....

gas **B**. .....

[2]

(b) Suggest why the amount of water vapour present in air is **not** constant.

.....

..... [1]

(c) Name a pollutant gas that may be found in air.  
State the source of this gas.

pollutant gas .....

source .....

[2]

5 An electric lamp produces heat and light.

(a) Name the form of energy that is converted into heat and light. .... [1]

(b) A lamp is rated as 100W.

(i) Calculate the amount of energy changed into heat and light in the lamp in 5.0 minutes.

amount of energy = ..... J [2]

(ii) The lamp produces 28 500 J of heat in the 5.0 minutes.

Calculate the amount of energy converted into light by the lamp.

amount of energy = ..... J [1]

6 (a) Insulin is produced by the pancreas. It acts in the liver, where it affects the conversion of blood glucose to stored carbohydrate.

(i) What type of substance is insulin?

..... [1]

(ii) How is insulin transported to the liver?

..... [1]

(iii) Which organ destroys the insulin after it has had its effect?

..... [1]

(b) Name the part of the eye that changes when

(i) a bright light suddenly shines on the eye,

.....

(ii) the eye adjusts from viewing a near object to viewing a distant object.

.....

[2]

- 7 Alkanes are obtained by the fractional distillation of petroleum (crude oil).  
Alkenes are made by cracking alkanes.

For  
Examiner's  
Use

(a) State **one** condition used in the cracking of alkanes. .... [1]

(b) State how the molecular structure of alkenes differs from the molecular structure of alkanes.

..... [1]

(c) Alkenes may be distinguished from alkanes by adding aqueous bromine.  
State the colour change when bromine is added to an alkene.

colour changes from ..... to ..... [2]

(d) Poly(ethene) is made from ethene by polymerisation.  
Explain the meaning of the term *polymerisation*.

.....  
..... [2]

- 8 A student performs an experiment to obtain an extension-load graph for a spring.

(a) State what measurements are made in order to determine the extension of the spring.

.....  
.....  
..... [1]

(b) The length of the spring with no load is 8.0 cm.  
Fig. 8.1 shows the length of the spring for different loads.  
Complete Fig. 8.1 by writing in the missing values of extension and load.

load/N	length/cm	extension/cm
1.0	9.2	
	15.2	7.2

Fig. 8.1

[2]

9 (a) The cotyledons of a seed contain an enzyme that digests starch.

(i) Name an enzyme that digests starch.

.....

(ii) Name the product of this digestion.

.....

[2]

(b) A piece of cotyledon was placed on a jelly containing starch.  
A second piece was boiled in water and cooled before being placed on the jelly.

After 24 hours, iodine solution was poured onto the jelly.  
Iodine and starch react to give a dark blue/black colour.  
Fig. 9.1 shows how the dish looked.

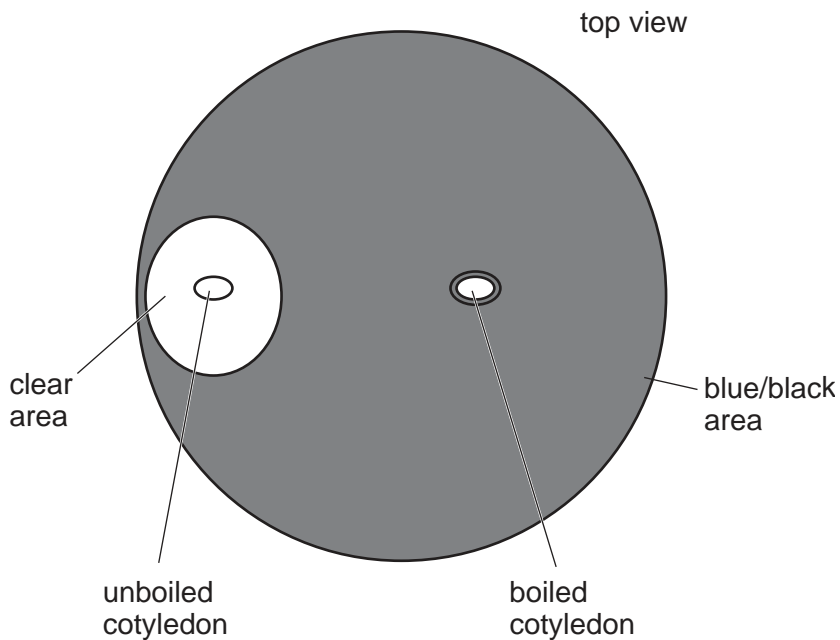

**Fig. 9.1**

Explain why there is a clear area around the unboiled cotyledon.

.....

.....

..... [2]

(c) Explain why there is no clear area around the boiled cotyledon.

.....

..... [2]

10 Study the following reaction scheme.

For  
Examiner's  
Use

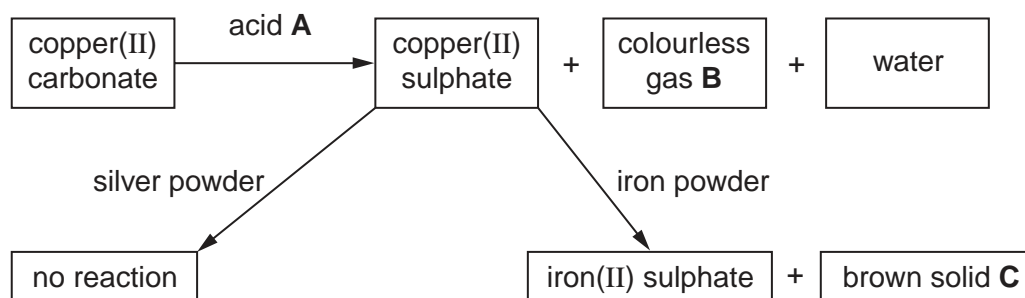

(a) Identify the substances **A**, **B** and **C**.

acid **A** .....

colourless gas **B** .....

brown solid **C** .....

[3]

(b) Suggest why the copper(II) sulphate solution reacts with iron but does **not** react with silver.

.....  
 .....  
 ..... [2]



- 11 Fig. 11.1 shows a magnet moving into a coil of wire. A sensitive ammeter measures the current in the coil.

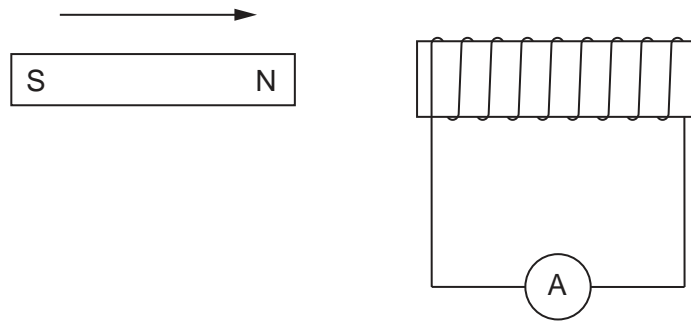

Fig. 11.1

Complete the following sentences using the words below.

You may use each word once, more than once, or not at all.

**broken      changing      constant      complete      high**  
**induces      low      produces      zero**

As the magnet moves into the coil, the ..... magnetic field inside the coil  
..... an e.m.f. in the circuit. Because the circuit is .....,  
a current is produced. The current is zero whenever the speed of the magnet is  
.....

[4]

12 Fig. 12.1 represents part of the carbon cycle.

For  
Examiner's  
Use

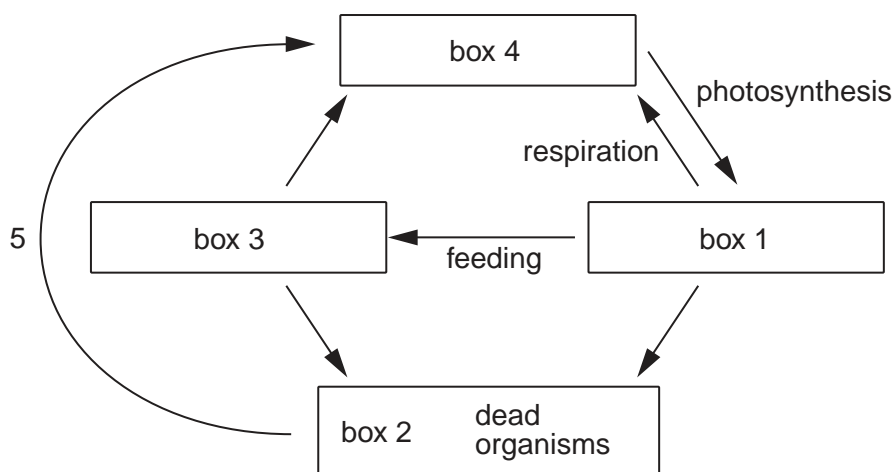

Fig. 12.1

(a) (i) What words should be written in the boxes labelled 1, 3 and 4?

box 1 .....

box 3 .....

box 4 .....

[3]

(ii) State the process that is represented by the arrow labelled 5.

..... [1]

(b) Name the substance in box 1 that contains carbon and is formed by photosynthesis.

..... [1]

- 13 Fig. 13.1 shows a force of 20 N being used to move a block of mass 5.0 kg across a horizontal frictionless surface.

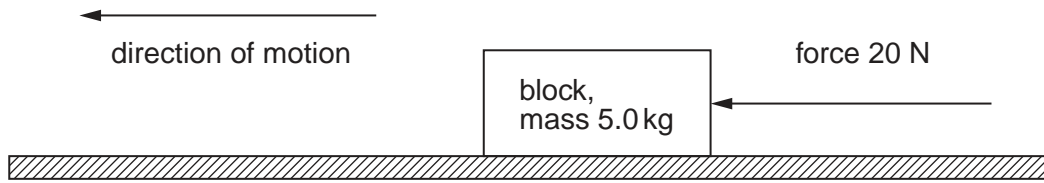

**Fig. 13.1**

- (a) Calculate the acceleration of the block.

acceleration = ..... [3]

- (b) On Earth, the gravitational field strength  $g = 10 \text{ N/kg}$ .

Calculate the weight of the block.

weight = ..... N [1]

- (c) The force of 20 N moves the block a distance of 40 cm.

Calculate the work done by the force.

work done = ..... [2]

- 14 A rocket explodes 99 m above the ground. Both light and sound are produced at the same time.

For  
Examiner's  
Use

The speed of sound is 330 m/s.

- (a) (i) Explain why the explosion of the rocket is seen by a boy on the ground before he hears it exploding.

.....  
..... [1]

- (ii) Calculate the shortest time that the sound takes to reach the ground.

time = ..... s [2]

- (b) The light emitted by the exploding rocket has many different frequencies.

State what is meant by the *frequency* of a wave.

.....  
..... [1]

- (c) Visible light is one component of the electromagnetic spectrum.

Name a component

(i) with a longer wavelength than visible light, .....

(ii) that is emitted from some radioactive nuclei. ....

[2]

15 Fig. 15.1 shows a cross-section through a flower.

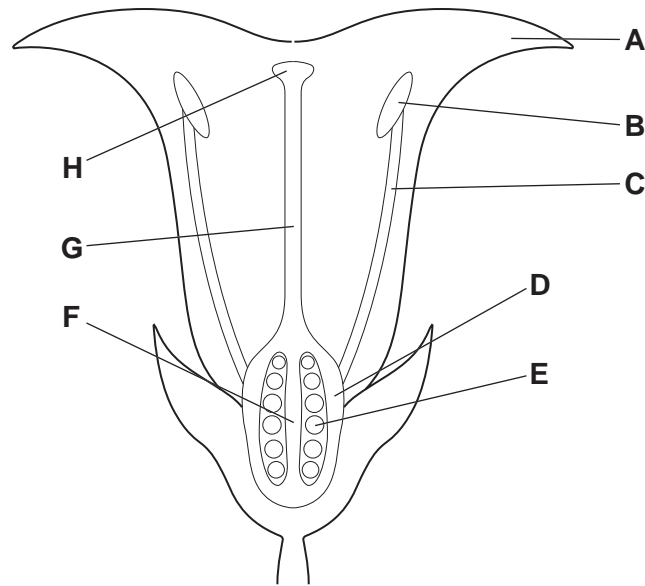

Fig. 15.1

(a) (i) Give the letters of the structures that contain cells with nuclei which fuse during sexual reproduction?

..... and ..... [2]

(ii) Name the structure that is formed by the fusion of the nuclei of these two cells.

..... [1]

(b) Into what do each of the structures labelled **D** and **E** develop?

**D** develops into .....

**E** develops into .....

[2]

16  $^{16}\text{O}$  and  $^{18}\text{O}$  are isotopes of the element oxygen.

(a) State how the two isotopes are different.

.....  
..... [1]

(b) Explain why the two isotopes have the same chemical properties.

.....  
..... [2]

(c) State the electronic structure of  $^{16}\text{O}$ . ..... [1]

(d) State the relationship between the electronic arrangement of an oxygen atom and the group that oxygen belongs to in the Periodic Table.

.....  
..... [1]

17 Fig. 17.1 shows a root hair cell.

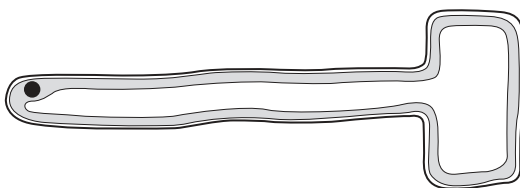

Fig. 17.1

(a) State two substances that are absorbed by a root hair cell.

1. ....  
2. .... [2]

(b) State two features of a root hair cell that make it suitable for absorption.

1. ....  
.....  
2. ....  
..... [2]

18 (a) Fig. 18.1 shows a ray of light from a pin that is incident on a plane mirror at point A.

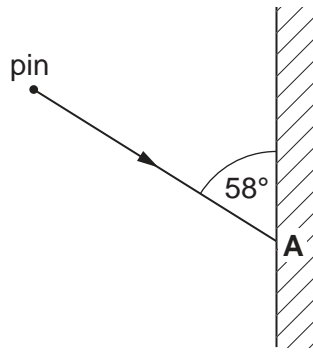

Fig. 18.1

- (i) On Fig. 18.1, draw the normal to the mirror at A. [1]
- (ii) On Fig. 18.1, mark the position of the image of the pin as seen in the mirror. [2]
- (iii) Calculate the angle of incidence.

angle of incidence = .....° [1]

(b) Fig. 18.2 shows a ray of light entering a parallel-sided glass block.



Fig. 18.2

Complete Fig. 18.2 to show the path of the ray inside the block and after leaving the block. [2]

19 (a) Define *relative atomic mass*,  $A_r$ .

.....  
 ..... [2]

For  
Examiner's  
Use

(b) Sodium reacts with water to produce sodium hydroxide solution and hydrogen.  
 The equation for the reaction is

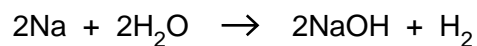

(i) Calculate the relative molecular mass of sodium hydroxide.  
 ( $A_r$ : H, 1; Na, 23; O, 16.)

..... [1]

(ii) Calculate the mass of water required to react with 4.6 g of sodium.  
 ( $A_r$ : Na, 23.)

mass = ..... g [2]

(c) State a test to show that sodium hydroxide solution is alkaline.

test .....

result .....

[2]







**BLANK PAGE**

---

Permission to reproduce items where third-party owned material protected by copyright is included has been sought and cleared where possible. Every reasonable effort has been made by the publisher (UCLES) to trace copyright holders, but if any items requiring clearance have unwittingly been included, the publisher will be pleased to make amends at the earliest possible opportunity.

University of Cambridge International Examinations is part of the Cambridge Assessment Group. Cambridge Assessment is the brand name of University of Cambridge Local Examinations Syndicate (UCLES), which is itself a department of the University of Cambridge.

